

HotShield PTC™

High Operating Temperature
Smoke Management and Fire Dampers

Features

- Smoke Management and Fire Dampers operational up to 300°C for a period of 1 or 2 hours (two versions available).
- Thermally insulated electric Control Modes.
- Pneumatic option available 250°C for one hour.
- Halogen free low smoke and fume cabling supplied as a standard feature.
- Low closed blade leakage.
- Dampers when closed are compliant to BS 476 Part 20 Fire Damper Test Standard.
- Actionpac Damper Control System compatibility.
- HotShield Vent PTC™ reverse action dampers for High Operating Temperature Smoke Control and Extract applications.
- HotShield Damper Interface (HDI) enclosure. Unique Actionair Interface heat protection.



STAR GLORY TECHNOLOGIES LTD.

Rm1702., 17/F., 41-47 Marble Road
North Point, Hong Kong
Tel.: 3427 5028 / Fax.: 2146 5050
Email: info@starglory.net
Website: www.starglory.net

actionair

Dampers Controls Fancoils

Ruskin Air Management Limited
www.ruskinuk.co.uk

Introduction

Actionair have developed a new technically advanced thermal enclosure that actually has the ability to absorb heat energy when subjected to a high temperature environment.

The performance criteria involves continuous operation of the complete damper and actuator assembly at elevated temperatures.

This new enclosure is made from a phenolic composite resin with excellent endothermic properties. A chemical reaction occurs within the insulating material when it is heated. This reaction has the effect of lowering the temperature inside the enclosure, thus prolonging the duration of the actuator's operation at elevated temperatures.

Smoke and other products of combustion kill at least 80% of recorded 'fire victims', smoke is debilitating and can render people unconscious minimising their chances of survival. Many more die weeks or months later from the lingering effects and toxic effects of smoke inhalation.

Smoke and toxic gases – **the Silent Killers** – have to be managed and controlled quickly and effectively to avoid confusion and panic from the threat posed to life safety and the extraction and control of these deadly gases is of paramount importance for the safe evacuation of the buildings occupants.

Application

HotShield PTC™ High Operating Temperature Smoke Management and Fire Dampers are designed for installation in high temperature ductwork systems with mechanical smoke extraction. As these ductwork systems regularly serve more than one fire zone or floor when smoke extraction is conducted from one area, it is essential to fully fire protect adjoining fire zones from ductwork penetrations that are connected to the smoke extract duct.

For this purpose HotShield PTC™ dampers, when closed are a fire rated damper to BS 476 part 20 for up to 2 hours, thus providing the fire isolation required. Closure of the damper is achieved by removal/loss of the electrical supply. When used for smoke extraction, under authorised control, the HotShield PTC™ damper will remain open under electrical power for a period of 1 or 2 hours at temperatures of up to 300 °C thus allowing the safe extraction of smoke

The importance of the subsequent smoke damage that can occur to adjacent property and fittings is also recognised, as this can have disastrous effects on homes and businesses as recognised in the Loss Prevention Council Design Guide for Fire Protection in Buildings.

Actionair have developed the HotShield PTC™ High Temperature Smoke Management and Fire Dampers along with the HotShield Vent PTC™ Smoke Control and Extract Dampers to enable the concepts of fire engineering to be employed in ducted smoke ventilation systems.

These dampers designed, tested and approved to deliver high temperature operation at up to 300 °C for 1 and 2 hours, provide the designer with the capability of extracting hot smoke and combustion gases through a common smoke extraction duct linked to adjacent fire zones and floors.

As smoke can spread rapidly and efficiently through a building ductwork system, damper operation needs to be initiated by a smoke detection system, as thermal sensing can often be too late. HotShield PTC™ and HotShield Vent PTC™ dampers are designed to be interfaced with a smoke detection/fire alarm system.

and hot gases of combustion through the extended fire compartment created by the fire rated ductwork.

HotShield PTC™ Smoke Management Fire Dampers may also be used for controlled supply of make up air as a function of the fire engineering process.

HotShield Vent PTC™ High Operating Temperature Smoke Control and Extract Dampers provide flexible smoke management where other fire compartments are not interconnected to a common fire rated ductwork system. Designed to spring to the open position by stored energy and remain closed when powered. HotShield Vent PTC™ dampers allow controlled smoke extraction to take place with a dedicated smoke control system if required, but retaining low leak closure of the smoke extract duct penetrations into the protected space during normal conditions.

Casings Features

With double skin spigotted galvanised steel (to BS EN 10142) casing the HotShield PTC™ dampers comply to Class A and B of Eurovent Document 2/2 and Test Procedures for Classes A, B and C of HVCA Ductwork Specification DW144. Damper casings are manufactured with fully welded spigotted connections suitable for Square, Rectangular, Circular and Flat Oval duct connections. As an extra cost option, casings can be manufactured in 430 grade (Type 1.4016) Ferritic or 316 grade (Type 1.4401) Austenitic stainless steel, 1.2mm thick.

Blade Features

The Damper blades are aerodynamic, double skin 430 grade (Type 1.4016) to BS EN 10088-2 Ferritic stainless steel which are 75mm deep and interlock to form a positive smoke and fire resisting shield. Incorporated within the blade profile is a silicone seal to ensure low closed blade leakage at temperatures up to 300 °C for 1 or 2 hours. Stainless steel blade end bearings and peripheral gasketing maintain the low closed blade leakage allowing for expansion under full fire conditions. Optional Blade construction 316 grade (Type 1.4401) Austenitic Stainless Steel.

Proportional Torque Control

A new generation High Operating Temperature Smoke Management and Fire Damper, thermally Insulated Control Mode assembly, with a unique and dedicated Proportional Torque Control for optimised Damper/Control Mode torque performance. The unique *snaplock™* drive interface ensures user friendly, easy and secure connection of the Control Mode to the damper. The drive interface, which is totally independent of the ductwork, and provides ease of connection to square, rectangular, circular and flat oval ductwork, including fire rated Ductwork.

Parameters

HotShield PTC™ and HotShield Vent PTC™ Dampers to maximum width and height dimensions (see page 6) can be used where the operating total system pressure is up to 1500 Pascals and duct velocities to 15m/second.

As with any life safety damper product, a suitable planned inspection programme should be implemented. For specialist and/or aggressive applications, please refer to Actionair Sales Office.

Control Options

A choice of a 24V or 230V Control Modes located outside the ductwork and (protected by its own thermally insulated enclosure) and Halogen Free Low Smoke and Fume cables, allows HotShield PTC™ Damper control up to 300 °C for a period of 1 or 2 hours. The Control Mode upon receipt of the

relevant supply voltage will motor the Damper to the open position. Closure of the Damper is achieved by removal/loss of the electrical supply.

The Damper when closed will provide protection in accordance with BS 476 Part 20. Control Modes have two separate volt free contacts for the

provision of external damper status indication. (No thermal links available).

HotShield Vent PTC™ Dampers and associated Control Modes are reverse action with spring opening.

HotShield and Hot/Vent/Shield

HM5 PTC	10W (12.5VA) 24V	end switches SPDT 250V 6(3)A	HotShield	Power Off – Fail-safe Close	■
HM6 PTC	12W (14VA) 230V	end switches SPDT 250V 6(3)A	HotShield	Power Off – Fail-safe Close	■
HMV5 PTC Vent 1	10W (12.5VA) 24V	end switches SPDT 250V 6(3)A	Hot/VentShield	Power Off – Fail-safe Open	■
HMV6 PTC Vent	12W (14VA) 230V	end switches SPDT 250V 6(3)A	Hot/VentShield	Power Off – Fail-safe Open	■
HM5-2H PTC	10W (12.5VA) 24V	end switches SPDT 250V 6(3)A	HotShield	Power Off – Fail-safe Close	■
HM6-2H PTC	12W (14VA) 230V	end switches SPDT 250V 6(3)A	HotShield	Power Off – Fail-safe Close	■
HMV5-2H PTC Vent	10W (12.5VA) 24V	end switches SPDT 250V 6(3)A	Hot/VentShield	Power Off – Fail-safe Open	■
HMV6-2H PTC Vent	12W (14VA) 230V	end switches SPDT 250V 6(3)A	Hot/VentShield	Power Off – Fail-safe Open	■

■ ■ See wiring detail on page 4.

HotShield and Hot/VentShield Control Modes HM5 PTC and HM6 PTC (operational for 1 hour @ 300 °C) and HM5 – 2H PTC and HM6 – 2H PTC (operational for 2 hours @ 300 °C) are NOT supplied with the Electrical Thermal Release (ETR). They Fail-safe when the power is off/interrupted).

HotShield and Hot/VentShield

HM5-3P PTC	24V 7W (10VA) end switches SPDT 250V 6(3)A	HotShield	Power Off – Fail-safe Close	2-10V Set position
HMV5-3P PTC Vent	24V 7W (10VA) end switches SPDT 250V 6(3)A	Hot/VentShield	Power Off – Fail-safe Open	2-10V Set position

HotShield and Hot/VentShield Control Modes HM5 – 3P PTC (operational for 1 hour @ 300 °C) are NOT supplied with Electrical Thermal Release (ETR) and Fail-safe when the power is off/interrupted. NOTE: 1 hour version only available.

HotShield and Hot/VentShield 2 Position Drive Open / Drive Closed

HM5-2P PTC	24V 7W (10VA), end switches SPDT 250V 6(3)A
HM6-2P PTC	230V 8W (12.5VA), end switches SPDT 250V 6(3)A

HM5-2P and HM6-2P are NOT supplied with ETR and remain in the desired emergency position when power is interrupted. (Operational for 1 hour at 300°C).

HM9 PTC Pneumatic Air Off – Fail-safe Close

HMV9 PTC Vent Pneumatic Air Off – Fail-safe Open

Pneumatic version rated at 250 °C for 1 hour.

Damper/Control Mode Interface

HotShield PTC™ Damper with unique snaplock™ Damper/Control Mode Interface

The Actionair unique *snaplock™* drive interface ensures user friendly, easy and secure connection of the Control Mode to the damper.

The drive interface which is totally independent of the ductwork, eliminates the need for costly dedicated duct sections, and provides ease of connection to square, rectangular, circular and flat oval ductwork.

The drive interface can be used up to wall thicknesses of 250mm. The interface

Position 1
Vertically down

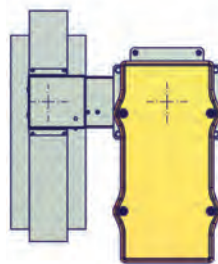

Position 2 Horizontal
Supplied as standard

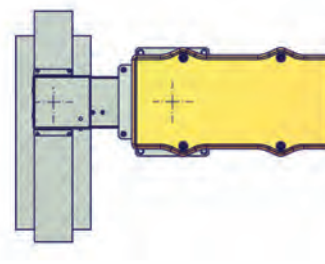

Position 3
Vertically up

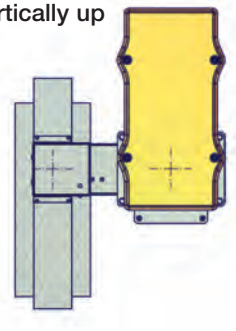

allows the Control Modes be fitted in any one of three orientations i.e.

Vertically down, Position 1
Horizontally, Position 2, (standard) or
Vertically up, Position 3.

This can be simply and easily carried out on site, by the using Actionair “multi

positions kit”. Full details on see pages 10 and 11) *This flexibility ensures that the damper and control mode require the minimal amount of room.*

This drive interface also guarantees that only the correct and certified Actionair products can be used.

Application and Wiring

Mode HM5 (24V System) and HM5 2H

Supply On – Damper motors open.
Supply Off – Spring closure.

Cable specification:

Si HF Low Smoke and Fume, Halogen Free, to IEC 754-1. Conforming to 73/23/EEC directive.

Release Time ≈ 22 secs.

Reset Time ≈ 60 secs.

(Connect 24V via a safety isolating transformer.)

IP54 Rated

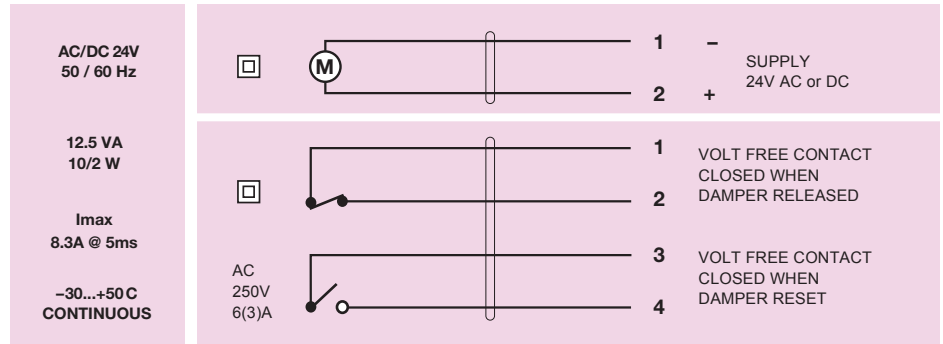

Mode HM6 (230V System) and HM6 2H

Supply On – Damper motors open.
Supply Off – Spring closure.

Cable specification:

Si HF Low Smoke and Fume, Halogen Free, to IEC 754-1. Conforming to 73/23/EEC directive.

Release Time ≈ 22 secs.

Reset Time ≈ 60 secs.

(To isolate from main power supply, the system must incorporate a device which disconnects the phase conductors, with a least 3mm contact gap.)

IP54 Rated

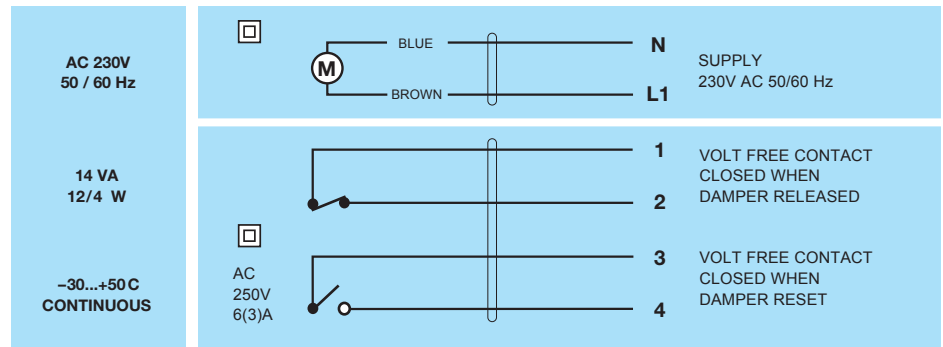

Multiple Assemblies

Square and rectangular casings are available in multiple module arrangements, supplied complete with blanking strips for site assembly by others. Additional support as well as provision for thermal expansion (4mm/metre) should be allowed for on multiple assemblies.

Multiple assemblies require installation approval by the relevant local authority.

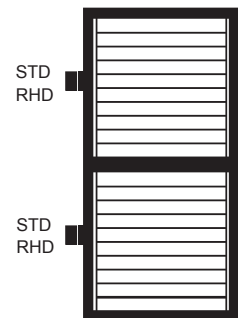
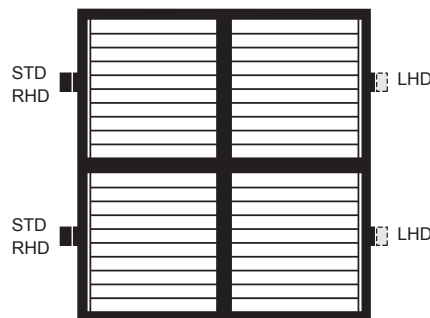
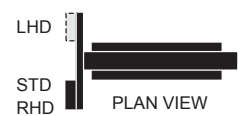

Approximate Weights (kg)

Square or Circular Duct Size (mm)	100	150	200	250	300	350	400	450	500	550	600	650	70	750	850	850	900	950	1000
Series 2501 Square	3.4	3.4	3.4	4.2	4.8	5.6	6.5	7.4	8.6	9.6	10.8	12.4	13.6	14.9	16.2	17.7	19.2	20.8	23.5
Series 2501 Square + Installation Frame	6.2	6.2	6.2	7.4	8.7	10.3	11.9	13.2	14.6	16.3	18.5	20.5	22.1	24.0	25.9	28.1	30.3	32.4	34.5
Series 2601 Circular	5.3	5.3	5.3	6.1	7.2	8.4	9.6	11.2	12.6	14.0	15.9	17.5	19.1	20.7	22.5	24.3	26.2	29.3	32.1
Series 2601 Circular + Installation Frame	8.5	8.5	8.5	10.0	11.9	13.7	15.4	17.1	19.2	21.8	24.0	26.0	28.2	30.4	32.8	35.3	37.8	40.3	43.1

Control Modes 5 and 6 7.6 Kg (including drive interface)

HotShield Damper Interface Enclosure (HDI)

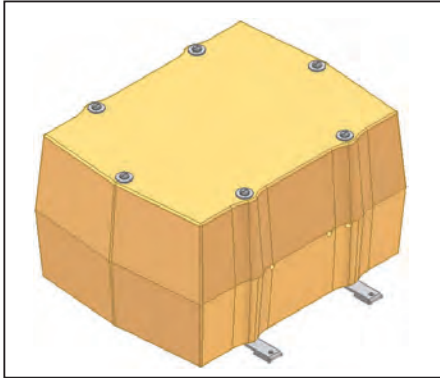

Actionair have developed a unique thermal enclosure to protect the Actionpac LNS range of damper interfaces currently available.

The enclosure consists of two separate materials, enabling the HDI to function at the extreme temperature specified. The outer casing has endothermic properties that significantly slow down the internal temperature rise in a high temperature emergency condition. The inner casing is a special thermal insulating material.

The maximum temperature is 300°C for up to one hour. This has been tested and independently witnessed by BRE (Ref Test No. 221067A).

The HDI enclosure is to be used in HotShield PTC™ applications where the Actionpac LNS system is being used to control the dampers.



SFDI Unit

SFDIs and SDIs, can be installed within the HDI enclosure.

The HDI can be mounted in any orientation, on a flat surface or alternative suitable mounting system.

The SFDI, or SDI units are supplied without the damper interface electronics, which will be supplied separately at commissioning stage.

Maximum normal external operating temperature: 30°C.

Total Weight (including internal DIs) = 11.5Kg (approx).

Sectional View of HDI Enclosure

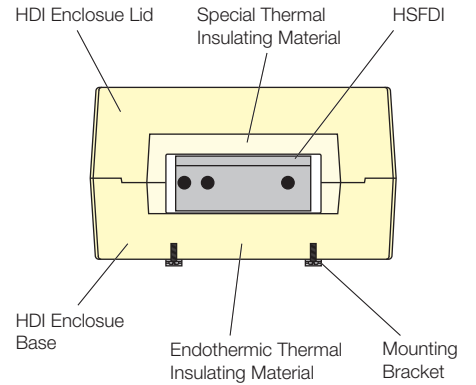

Typical Installation

1. Fix the 2 off mounting brackets provided, to the underside of the HDI enclosure, by screwing into the threaded inserts with the M5 screws provided.
2. Allowing suitable cable access around the HDI enclosure, position it in desired location, and mark fixings positions using the bracket holes as a template.
3. Remove HDI enclosure lid by unscrewing the 6 off long screws/large flat washers
4. Securely mount the HDI base in its intended position. Hole specification and fixings by others.
5. Remove DI/CMS lid.
6. Connect cables and refit DI lid in accordance with Actionpac catalogue information.
7. Refit HDI enclosure lid with the 6 off screws/large flat washers, taking care to position cables in grooves. The inside insulation is sufficiently soft to compress locally around cables when the lid is screwed down.

Note: HDI lid may need to be removed and refitted again during testing/commissioning.

Dimensions

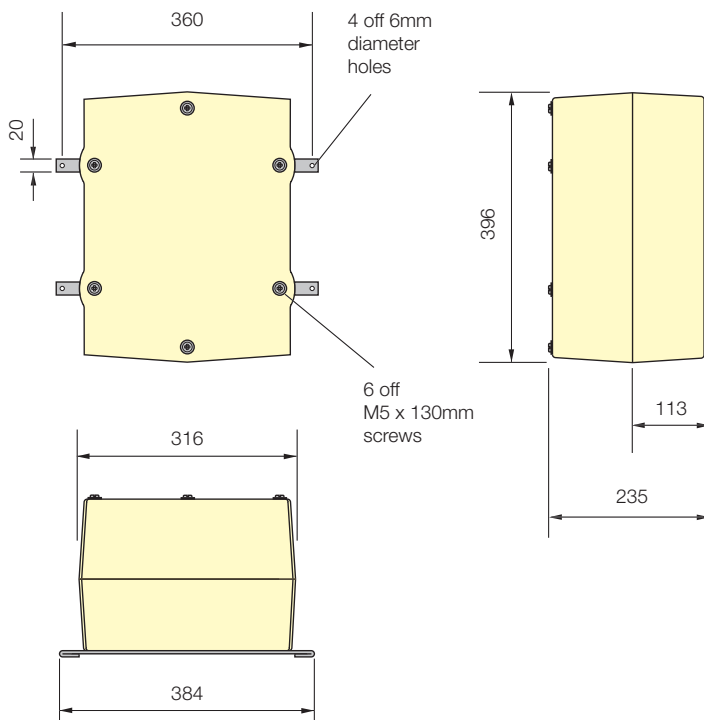

Installation Systems

Popular types of Installation Frame that are available.

DWFX™ (DRY WALL FIX) Installation System

Typically for installation into Dry Wall, Stud Partitions.

HEVAC / HVCA Galvanised Steel Installation Frames

Typically for installation into Blockwork, Concrete walls and floors.

DWFX-F (Dry Wall FIX - Frame)



DWFX-C (Dry Wall FIX - Cleat)



DWFX-F Dimensional Data

See page 8 and 9.

DWFX-C Dimensional Data

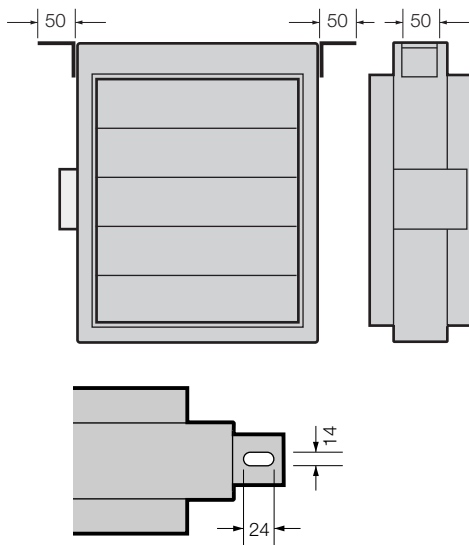

Specification

The Actionair DWFX-F installation method is BRE assessed to BS476 Pt 20/22 for 90 minutes (BRE assessment no. 225283).

The Actionair DWFX-F consists of a 1.2 mm galvanised steel peripheral flange with 50mm x 50mm x 3mm steel angle cleats with 14mm x 24mm oval slots, welded to damper casing for drop rod support.

Specification

The Actionair DWFX-C consists of 50mm x 50mm x 3mm steel angle cleats with 14mm x 24mm oval slots.

Fully welded to damper casing for drop rod support prior to wall construction.



Comprehensive literature, outlining installation and features, is available for our DWFX systems. Go to our website:-

www.actionair.co.uk

to view or download these as PDF files.

HEVAC / HVCA Galvanised Steel Installation Frames

Galvanised steel building ties permit stable handling, ease of transport and convenience of building in to the surrounding structure.

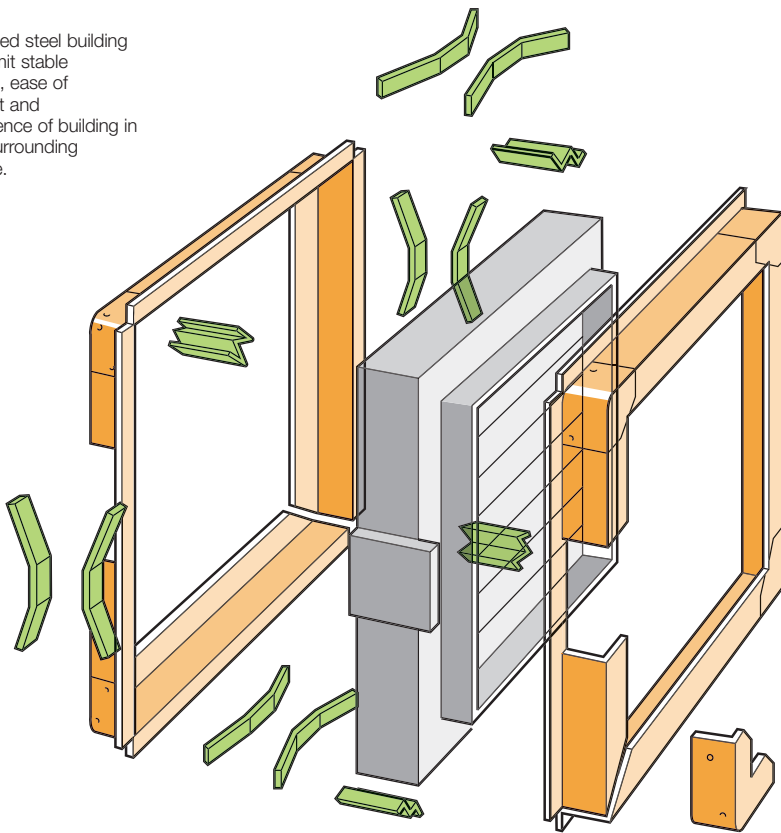

Galvanised Steel Installation Frames
(as required by HVC 6/5/83 Rev.1 July 1999.)

Installation frames are delivered to site as a complete assembly with the appropriate Damper fitted therein. The frame shall be installed centrally in the thickness of a brick, blockwork or concrete surrounding wall or floor, or in the case of thick walls or floors, so that the centre line of the frame

is at least 50mm away from the nearest face of the wall or floor in which the assembly is mounted. **The four tabs (building tie) forming each fixing point shall provide a positive fixing into the structure.** Multiple assembly dampers up to 1500 x 1500 or 2000 x 1000 can be fitted into fully assembled installation frames and delivered as one piece. Dampers in excess of these sizes will be

supplied in sections with the installation frame supplied in kit-form, Drg AA/F/8057. This drawing and method statement will be supplied for assembly to on site.

The maximum size of kit-form installation frames is 2500mm wide x 2000mm high.

- a. In brick or blockwork walls the tabs shall be bent out and solidly built into the mortar joints between the brick or blockwork.
- b. In the case of reinforced concrete walls and floors, the tabs shall be bent out and tied with wire to the reinforcing bars which will be deliberately left protruding into the opening.

The gap between the installation frame and builders work shall be backfilled with mortar or concrete on both sides of the flange.

Adjacent frame assemblies must be separated by builders work of a minimum thickness of 225mm (between installation frame upstand flanges) unless approval has been previously obtained from the appropriate Authority. For installations below this dimension please refer to Actionair Sales office.

In no case shall the HEVAC/HVCA frame and damper assembly be held in position merely by the adjacent ductwork, and it should be noted that in reinforced concrete structures (especially floors), it will not be sufficient to only backfill between the damper installation frame and the surrounding opening with mortar or fine aggregate concrete mix without provision for tying in the frame to the surrounding reinforced concrete structure.

Approved Installations

A binder containing approved installation illustrations is now available.

Refer to Actionair Sales Office or visit our website, www.actionair.co.uk The illustrations are under the heading PRODUCTS DRAWINGS.

Although the included methods have been tested and assessed, it is recommend, that these, as with all installation methods must be confirmed with Building Control /

Local Authority prior to manufacture. Actionair can also provide applications of other proposed methods of installation, please contact our Sales Office to discuss your specific requirements.

These again are the responsibility of the client to ensure that these are acceptable to Building Control / Local Authority before construction commences.



Dimensional Data

For Rectangular Dampers spigots are 5mm under duct size.

* Widths and heights available in 1mm increments.

Basic Dampers

Rectangular Dampers Series 2501 and 3501

For Ducts with widths of 100 – 150mm

For Ducts with heights of 100 – 150mm

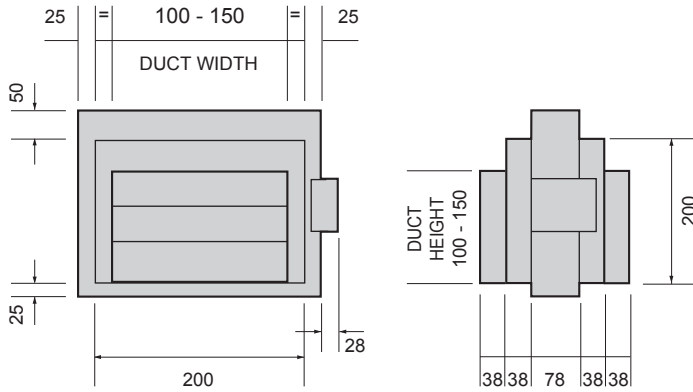

For Ducts with widths of 151 – 199mm

For Ducts with heights of 151 – 199mm

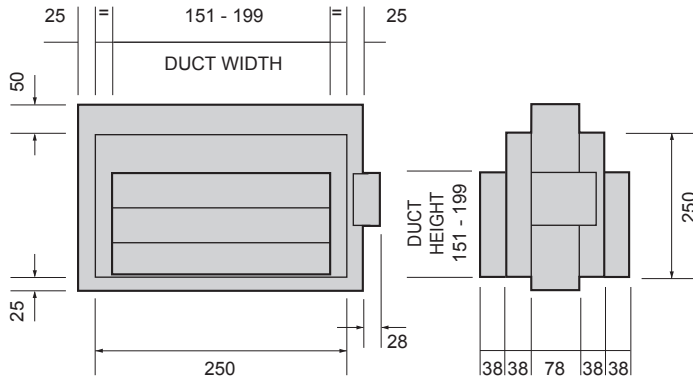

For Ducts with widths and heights of 200 – 1000mm

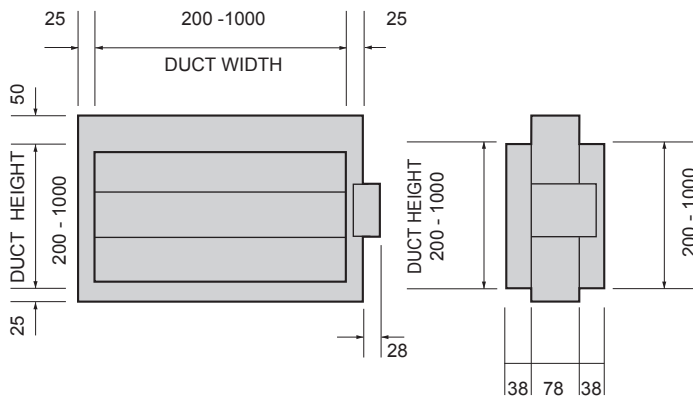

Dampers with Installation Systems

Dampers with DWFX-F

OVERALL FLANGE WIDTH = 370mm
OVERALL FLANGE HEIGHT = 395mm

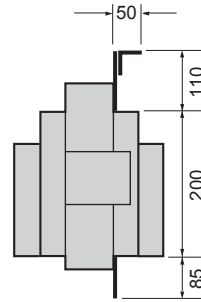

OVERALL FLANGE WIDTH = 420mm
OVERALL FLANGE HEIGHT = 445mm

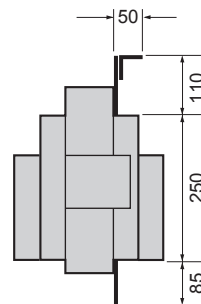

OVERALL FLANGE WIDTH = DUCT WIDTH + 170mm
OVERALL FLANGE HEIGHT = DUCT HEIGHT + 195mm

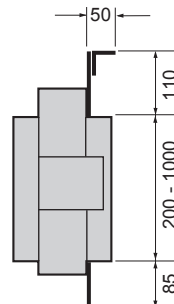

HEVAC / HVCA IF

OVERALL WIDTH OF INSTALLATION FRAME IS 316mm
OVERALL HEIGHT OF INSTALLATION FRAME IS 340mm

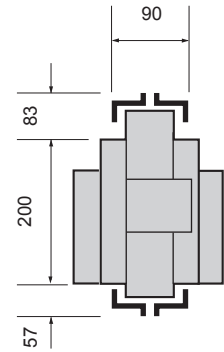

OVERALL WIDTH OF INSTALLATION FRAME IS 366mm
OVERALL HEIGHT OF INSTALLATION FRAME IS 390MM

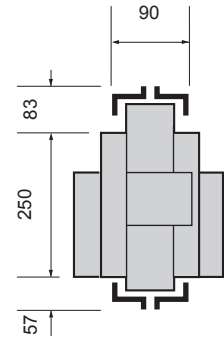

OVERALL WIDTH OF INSTALLATION FRAME IS DUCT WIDTH + 116mm
OVERALL HEIGHT OF INSTALLATION FRAME IS DUCT HEIGHT + 140MM

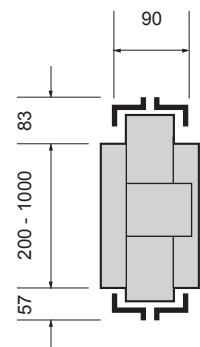

For Circular and Flat Oval Dampers spigots are 3mm under duct size.

Basic Dampers

Dampers with Installation Systems

Circular Dampers Series 2601 and 3601

Dampers with DWFX-F

HEVAC / HVCA IF

OVERALL FLANGE WIDTH = 370mm
OVERALL FLANGE HEIGHT = 395MM

OVERALL WIDTH OF INSTALLATION
FRAME IS 316mm
OVERALL HEIGHT OF INSTALLATION
FRAME IS 340mm

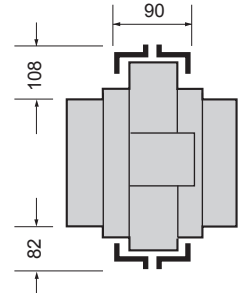
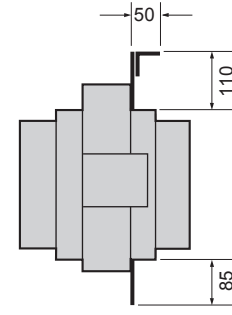
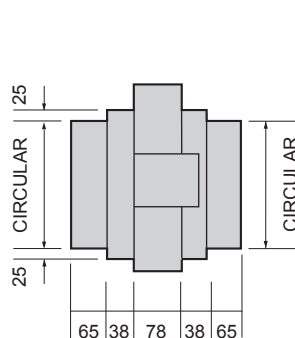
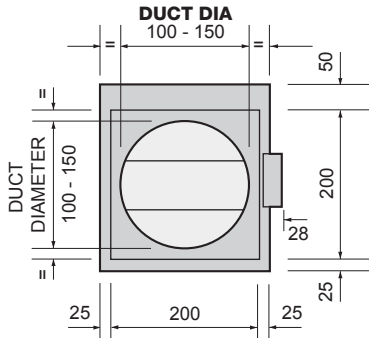

OVERALL FLANGE WIDTH = 420mm
OVERALL FLANGE HEIGHT = 445mm

OVERALL WIDTH OF INSTALLATION
FRAME IS 366mm
OVERALL HEIGHT OF INSTALLATION
FRAME IS 390mm

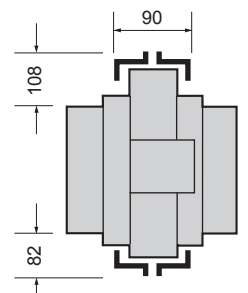
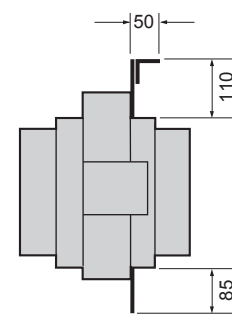
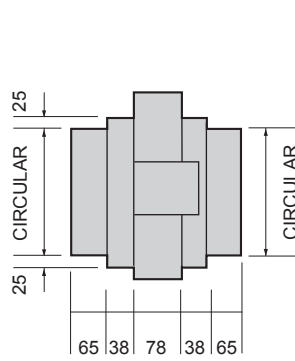
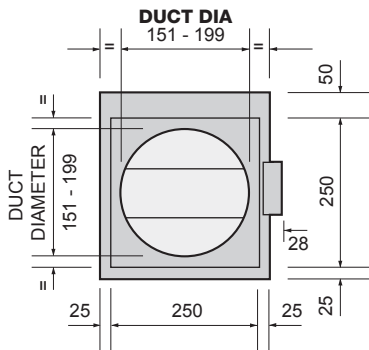

OVERALL FLANGE WIDTH =
DUCT DIA. + 220mm
OVERALL FLANGE HEIGHT =
DUCT DIA. + 245mm

OVERALL WIDTH OF INSTALLATION
FRAME IS DUCT DIA + 166mm
OVERALL HEIGHT OF INSTALLATION
FRAME IS DUCT DIA + 190mm

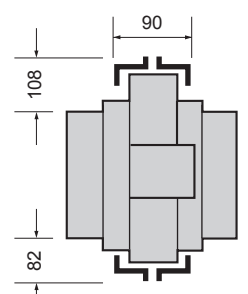
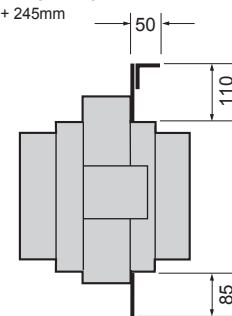
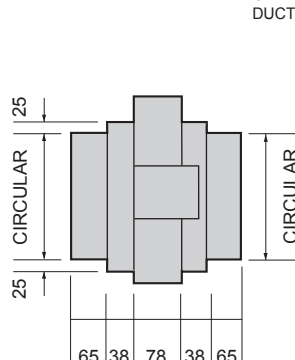
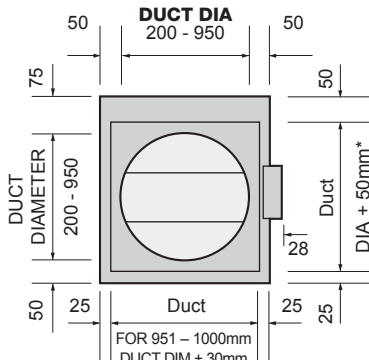

Flat Oval Dampers Series 2701 and 3701

OVERALL FLANGE WIDTH =
DUCT WIDTH + 220mm
OVERALL FLANGE HEIGHT =
DUCT HEIGHT + 245mm

OVERALL WIDTH OF INSTALLATION
FRAME IS DUCT WIDTH + 166mm
OVERALL HEIGHT OF INSTALLATION
FRAME IS DUCT HEIGHT + 190mm

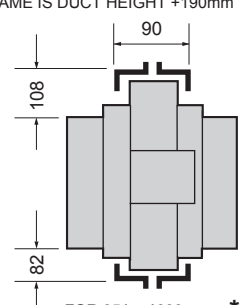
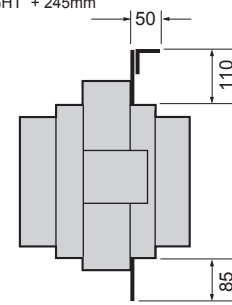
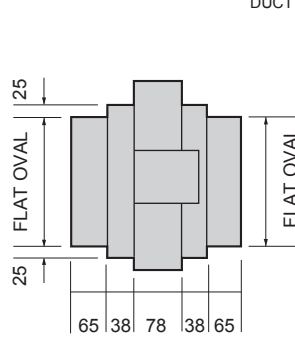
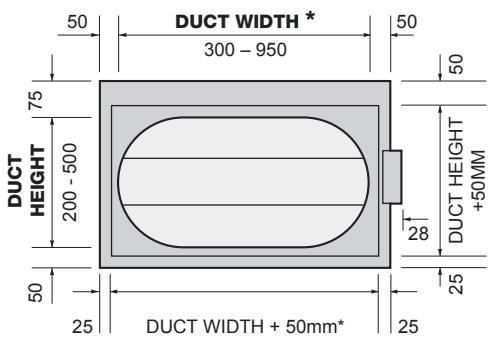

FOR 951 - 1000mm *
DUCT DIM + 30mm

Damper Installation and Control Mode Fitting

The Actionair unique *snaplock*™ drive interface ensures user friendly, easy and secure connection of the control mode to the damper.

The drive interface can be used up to wall thicknesses of 250mm. The drive interface allows the control modes to be fitted in any one of three orientations i.e.

- Vertically down, Position 1**
- Horizontally, Position 2, (standard) or**
- Vertically up, Position 3.**

A “multi positions kit” is required for positions 1 and 3 (for position 2 the “multi positions kit” is optional).

Typical Installation

1. Install the HotShield PTC™ Damper, complete with factory fitted damper shroud and transit plate, into the structure.
2. Connect and fit ductwork to damper spigots.
3. Remove transit plate and discard (recycle).
4. Slide the *snaplock*™ drive interface into the damper drive shroud. Pull the key ring on the easy pull lever, this *snaps* the drive interface into position.

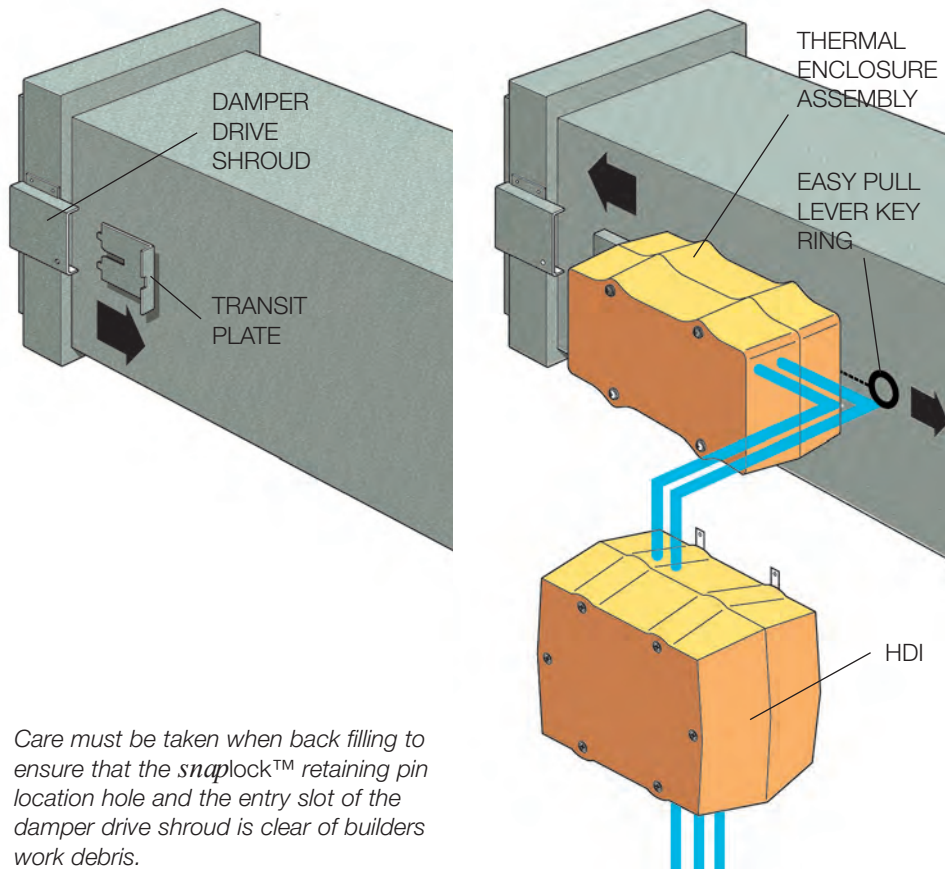

*Care must be taken when back filling to ensure that the *snaplock*™ retaining pin location hole and the entry slot of the damper drive shroud is clear of builders work debris.*

Changing the Control Mode of the HotShield PTC™ to position 1 and 3 on site:

1. Remove the 4 off M6 bolts and washers, lift off the thermal enclosure assembly,
2. Rotate the interface input shaft fully anti-clock wise.
3. Line up the output shaft slot on the underside of the interface with the slot on the interface plate.
4. Locate the thermal enclosure assembly to desired position and fix it to the mounting flanges with M6 bolts and washers.
5. Fully close the damper.
6. Pull the key ring on the easy pull lever, insert the interface assembly into the damper shroud, line up its dotted line with the end of the shroud, release the lever to lock.
7. Refer to standard O+M for testing.

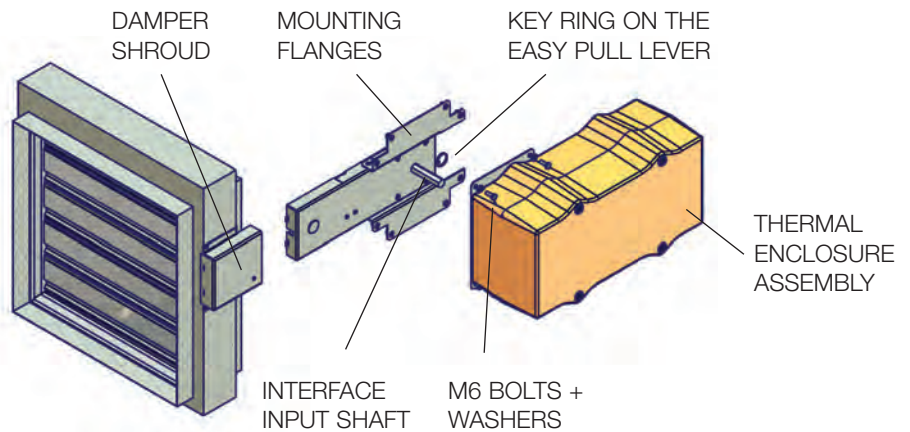

Reverse Mounting

The thermal enclosure and control mode can be reverse mounted using the “multi positions kit” onto the HotShield PTC™

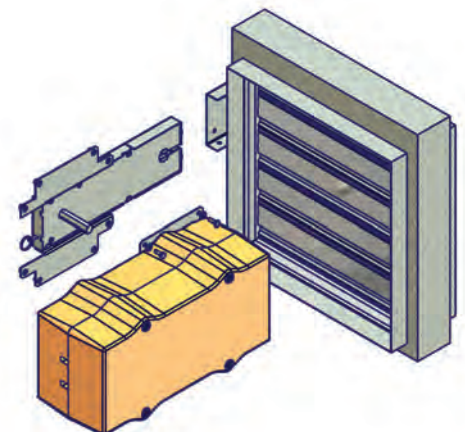

The information contained herein is subject to change without notice due to continuing research and development.

Damper, Interface and Thermal Enclosure Dimensions

POSITION 2 STANDARD
(WITHOUT MULTI POSITIONS KIT)

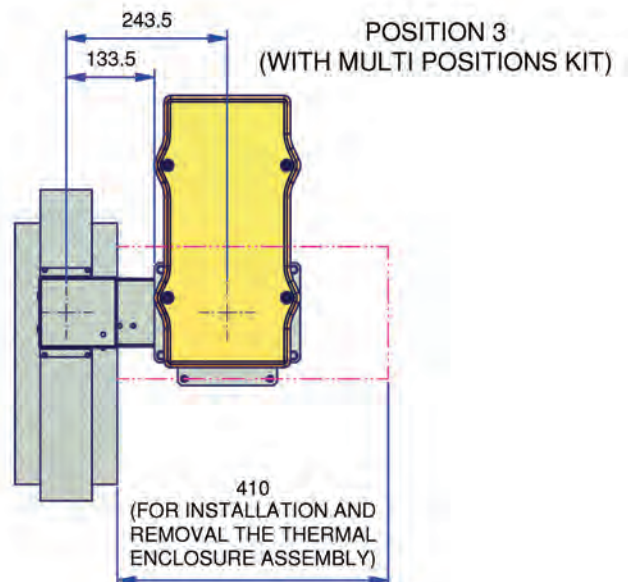
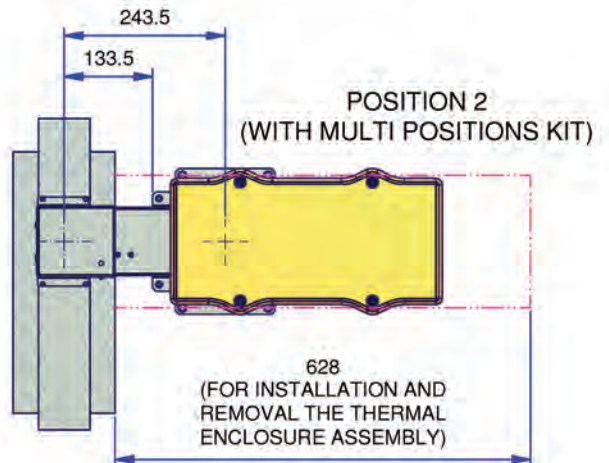
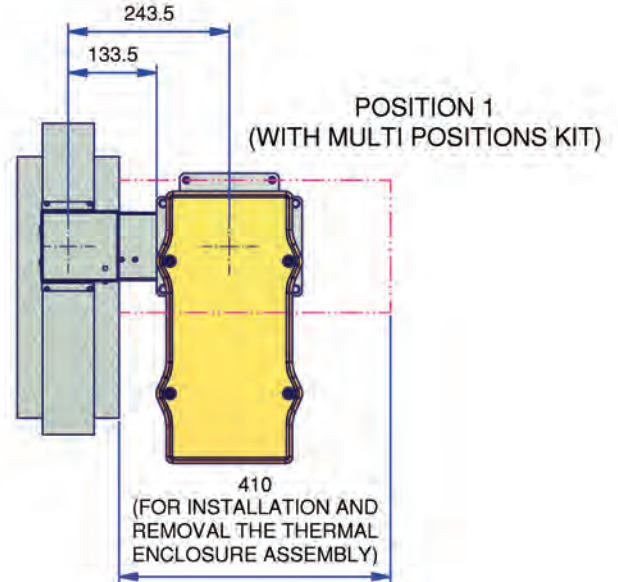
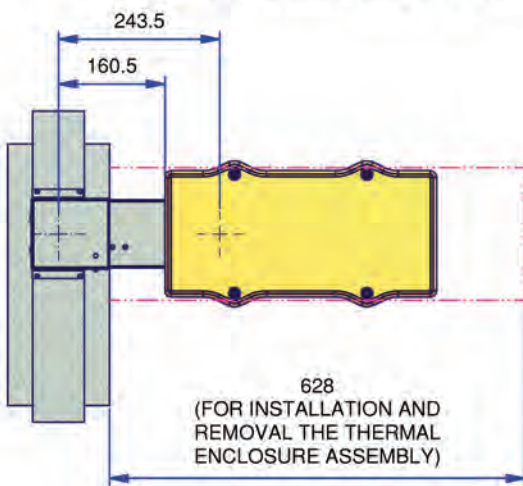

Note:

For HotShield PTC™, the control mode with the horizontal position 2 (without multi positions kit), will be standard, unless stated, otherwise this is the default option.

A multi positions kit for position 1, 2 and 3 is available. If the multi positions option is required, the control mode is sent out to position 2. It is easy to change to position 1 or 3 on site.

Maintenance

The HotShield PTC™ Dampers are designed for applications in normal dry filtered air systems and should be subjected to a planned inspection programme, with cleaning and light oil lubrication in accordance with BS9999. When exposed to fresh air intakes and/or inclement conditions this may need to be performed more regularly based on experience gained from previous inspections.

Acoustic Data

The data presented is from the Laboratory Determination of Acoustic and Aerodynamic Performance of HotShield PTC™ High Operating Temperature Smoke Management and Fire Dampers. A programme of extensive tests was carried out in the Reverberation Chamber and North Transmission Chamber of Sound research Laboratories Limited, Holbrook Hall, Sudbury, Suffolk, generally in accordance with BRITISH STANDARDS Nos. 4196, 4773, 4856, 4857 and 4954. This independent test facility is approved under the NAMAS Scheme.

From the selection of a duct velocity within the operational parameters of the damper a resultant pressure drop from Table 1 can be determined and the sum of these two components applied to the Velocity x Pressure Drop Vs Sound Power Level Graph. (Table 2)

The graph is the result of a full range of acoustic tests on HotShield PTC™ High Operating Temperature Smoke Management and Fire Dampers with the blades set in then fully open position.

The Spectrum Correction Data is applied to the number obtained from the graph and a complete Sound Spectrum of Flow Generated Noise for both Outlet (in duct) and Breakout (casing radiated) is obtained.

Example:

Duct with a design velocity of 8 m/sec. HotShield PTC™ Damper Series 2501 fully open.

Pressure Drop = 22 Pa (Table 1).
Multiply Velocity x Pressure Drop
 $8 \times 22 = 176$.

From Sound Power Graph (Table 2) plot 176 on horizontal Velocity/Pressure axis against 2501 outlet (in duct) graph to obtain 47 dBW on Vertical Sound Power Level Axis. Add or subtract corrections to the 47 dBW to provide full spectrum analysis.

Pressure Drop Vs Velocity

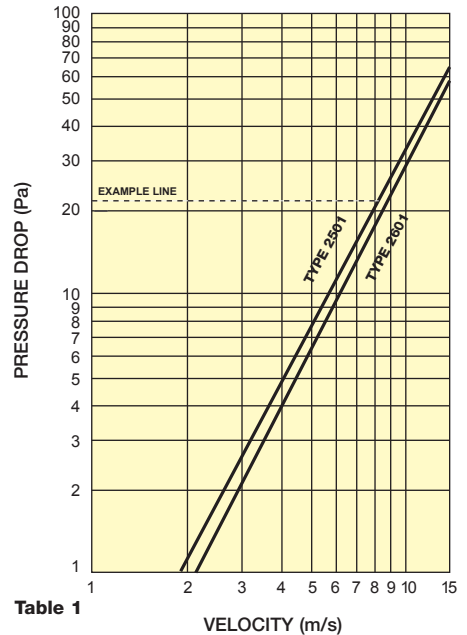

Table 1

Damper Leakage

HotShield PTC™ and HotShield Vent PTC™ closed blade leakage as tested on a damper 1000mm wide x 1000mm high.

Leakage Data at Ambient Temperature (Cold Smoke).

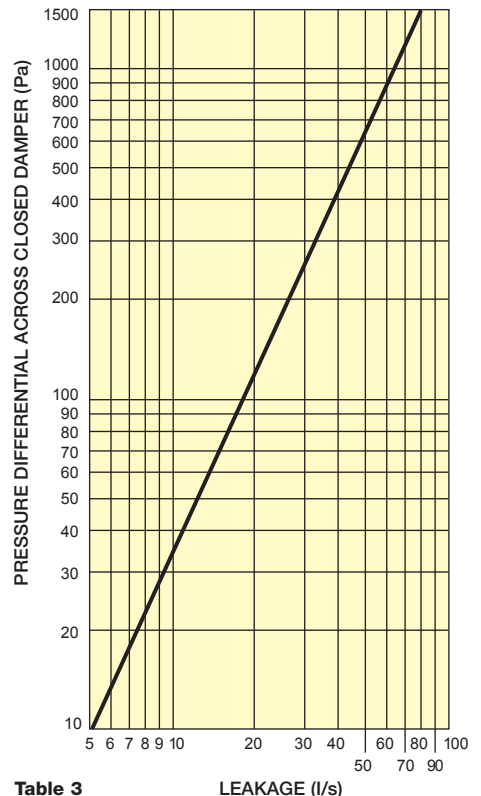

Table 3

Velocity (m/s) X Pressure Drop (Pa) Vs Sound Power Level (dBW)

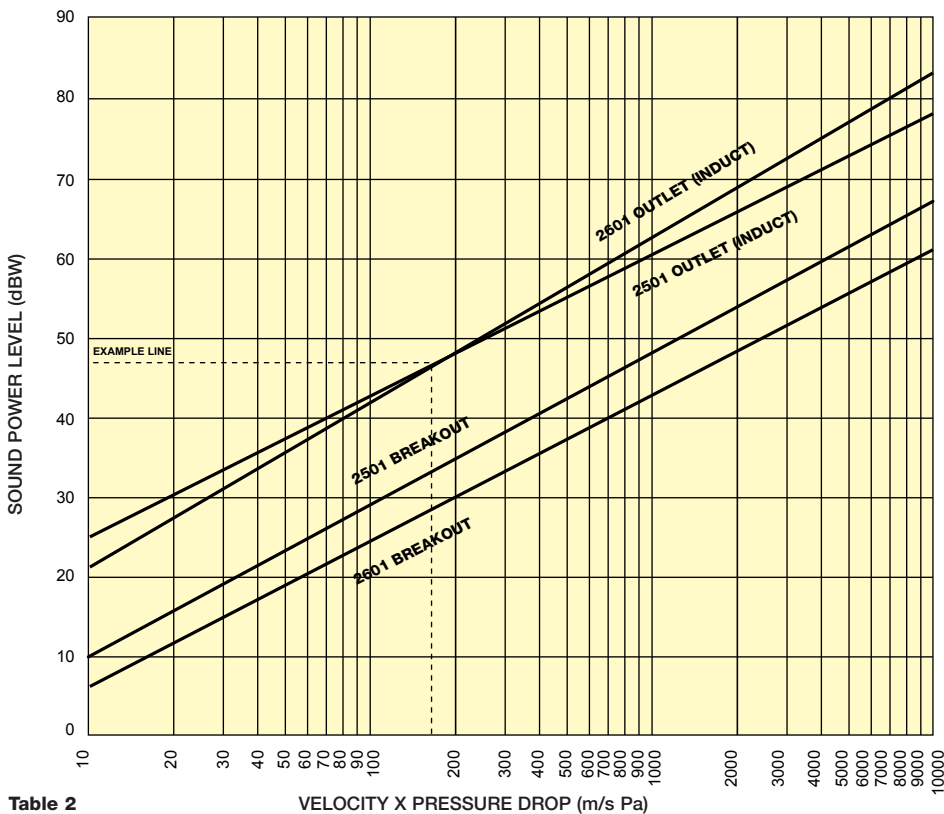

Table 2

HotShield PTC™ Outlet (Induct) Spectrum Corrections

Octave Band	63	125	250	500	1k	2k	4k	8k
Series 2501	+5	+4	+5	+5	+3	+1	-3	-5
Series 2601	+9	+4	+4	+5	+3	+1	-3	-6

HotShield PTC™ Breakout Spectrum Corrections

63	125	250	500	1k	2k	4k	8k	Hz
+8	+11	+9	+6	-3	-6	-14	-17	dB
+6	+10	+8	+4	-3	-3	-11	-14	dB

The leakage as detailed in Table 3 was achieved after a total immersion test at 300 °C for 1 hour (as witnessed by the Loss Prevention Council).

Specification

HotShield PTC™ High Operating Temperature Smoke Management and Fire Dampers comprising of 75mm stainless steel aerodynamic interlocking blades incorporating synthetic seal, with stainless steel blade end bearings and peripheral gasketing. Housed in a galvanised fully welded, spigotted casing suitable for square, rectangular, circular or flat oval connections.

The totally enclosed precise movement opposed blade drive shall be positioned out of the airstream for protection against damage, be hard wearing and free running.

The Control Mode/Damper connection shall be by means of the *snaplock™* drive interface mechanism, which is totally independent of the ductwork.

HotShield PTC™ High Operating Temperature Smoke Management and Fire Dampers in association with their appropriate insulated control modes shall be arranged for motor open and spring closed operation interfaced with a smoke detection/fire alarm system.

HotShield PTC Damper and selected thermally insulated Control Modes (HM5, HM5 2H, HM6 and HM6 2H) as supplied by Actionair.

HotShield Vent PTC™ High Operating Temperature Smoke Control and Extract Dampers comprising of 75mm stainless steel aerodynamic blades incorporating synthetic seal, with stainless steel blade end bearings and peripheral gasketing. Housed in a galvanised fully welded, spigotted casing suitable for square, rectangular, circular or flat oval connections.

The totally enclosed precise movement opposed blade drive shall be positioned out of the airstream for protection against damage, be hard wearing and free running.

The Control Mode/Damper connection shall be by means of the *snaplock™* drive interface mechanism, which is totally independent of the ductwork.

HotShield Vent PTC™ High Operating Temperature Smoke Control and Extract Dampers in association with their appropriate insulated control modes shall be arranged for motor close and spring open operation interfaced with a smoke detection/fire alarm system.

HotShield Vent PTC™ Damper and selected thermally insulated Control Modes (HVM5, HM5 2H, HM6 and HVM6 2H) as supplied by Actionair

Approvals

Approvals

Heat Degradation test witnessed by the Loss Prevention Council.

Complies with the latest DW 144 casing leakage specification.

HotShield PTC™ dampers, when closed, are compliant to BS 476 Part 20 Fire Damper Test Standards.

The insulated Control Modes satisfy the requirements of EN 50081-1 and EN 50082-1 electro magnetic compatibility.

Quality Assurance



Certification No.17
Assessed to ISO 9001



Customer Service

Actionair provides quality products backed by a dedicated team committed to providing the very best in customer service.

Offering experienced technical backup, comprehensive sales and administrative customer support, product commissioning and maintenance service.

Ordering Information

Example

Quantity	Series	Accessories	Duct Size	Control Mode
5	HS2501	IF	600(W) x 400(H)	HM6 2H
Number of units required	HS2501/PTC HotShield PTC™ Square or Rectangular (Motor Open/Spring Closure) HS2601/PTC HotShield PTC™ Circular (Motor Open/Spring Closure) HS2701/PTC HotShield PTC™ Flat Oval (Motor Open/Spring Closure)	IF Installation Frame DWFX-C™ Drywall Fix Cleat DWFX-F™ Drywall Fix Flange HDI Enclosure HSFDI	Nominal Damper Spigot Size	HM5 PTC HM6 PTC HMV5 PTC Vent HMV6 PTC Vent HM5-2H PTC HM6-2H PTC HMV5-2H PTC Vent HMV6-2H PTC Vent HM5-3P PTC HMV5-3P PTC Vent HM5-2P PTC HM6-2P PTC
	HSV3501/PTC HotShield Vent PTC™ Square or Rectangular (Motor Close/Spring Opening) HSV3601/PTC HotShield Vent PTC™ Circular (Motor Close/Spring Opening) HSV3701/PTC HotShield Vent PTC™ Flat Oval (Motor Close/Spring Opening)			For full descriptive list of Control Modes see page 3

Actionpac Damper Control Systems

Electro Mechanical Systems

Actionpac EMS - Standard Control and Monitoring System

Control and monitoring of Mode 5 or Mode 6 damper actuators in groups of 12, 24 or 36.

Actionpac EMB - Bespoke Control and Monitoring System Control Panel

The EMB Control Panels typically consists of the appropriate number of switches to provide individual or group control, LED indication for status monitoring and all necessary relays and timers to comply with the customer needs for fully or semi automatic damper operation. The EMB panels are purposely manufactured for any particular project to suit specific client requirements.

Addressable Systems

Actionpac 60/120 (LNS Standard) Intelligent Damper Control and Monitoring System

Actionpac 60 for the control/monitoring of up to 60 off Hot/SmokeShield dampers. Actionpac 120 for the control/monitoring of up to 120 off Hot/SmokeShield dampers.

Actionpac LNS3 Intelligent Damper Control and Monitoring System

The Actionpac LNS3 system represents a new generation of smoke/fire damper control. The system has been designed with the user in mind, providing an advanced tool that simplifies installation and commissioning of smoke/fire dampers and peripheral devices. The Panel PC operates on a Windows™ platform making it universally accepted and utilises solid state technology for optimum reliability.

It's server architecture delivers new benefits such as reduced commissioning time, simplified operation and scope for future growth.

The Actionpac LNS3 system is designed to protect life and property from damage caused by smoke and fire, by providing the means to:-

- Compartmentalise fire zones.
- Reduce the spread of smoke and fire.
- Keep escape routes and fire-fighting access open.
- Allow pressurisation and smoke extract by combined operation of dampers and fans.

Benefits

- Completely flexible to meet practically any building's damper requirements
- Three levels of alarm priority
- Panel PC driven system with real-time graphic displays
- Panel PC utilises solid state technology for optimum reliability
- Full configuration and diagnostics from Panel PC

- Optional automatic scheduled Damper testing
- Multiple wiring configurations to include Radial or Loop Topology
- Damper operational count provided
- Flexibility to accommodate any last minute changes to strategy, zones, damper quantities, references and descriptions etc.
- Powerful and flexible functionality enables standardisation of software (no bespoke site specific versions required)
- Cause and effect scenarios easily accommodated
- Multiple options for monitoring dampers, individually or by group or zone - output contacts can be triggered when a predefined percentage within a group or zone change position
- System designed to cater for environmental occupancy as well as the building's smoke/ fire strategy. RS232 BMS link provided enabling a BMS to link directly to the system to read damper positions etc.
- Optional remote access available
- Graphical User Interface displays live damper status and details as well as cause and effect strategies
- Text fields facilitate clear description of device references and locations
- System wide activity logged and viewable for diagnostics and maintenance
- Allows for phased commissioning and future expansion
- CE marked, LVD and EMC compliant



Actionpac LNS3 Intelligent Damper Control and Monitoring System

Fully comprehensive brochures are available on all Actionpac products. Visit the Actionair website [w.w.w.actionair.co.uk](http://www.actionair.co.uk) and download the relevant pdf.

General Schematic of Actionpac LNS3 Damper Control System

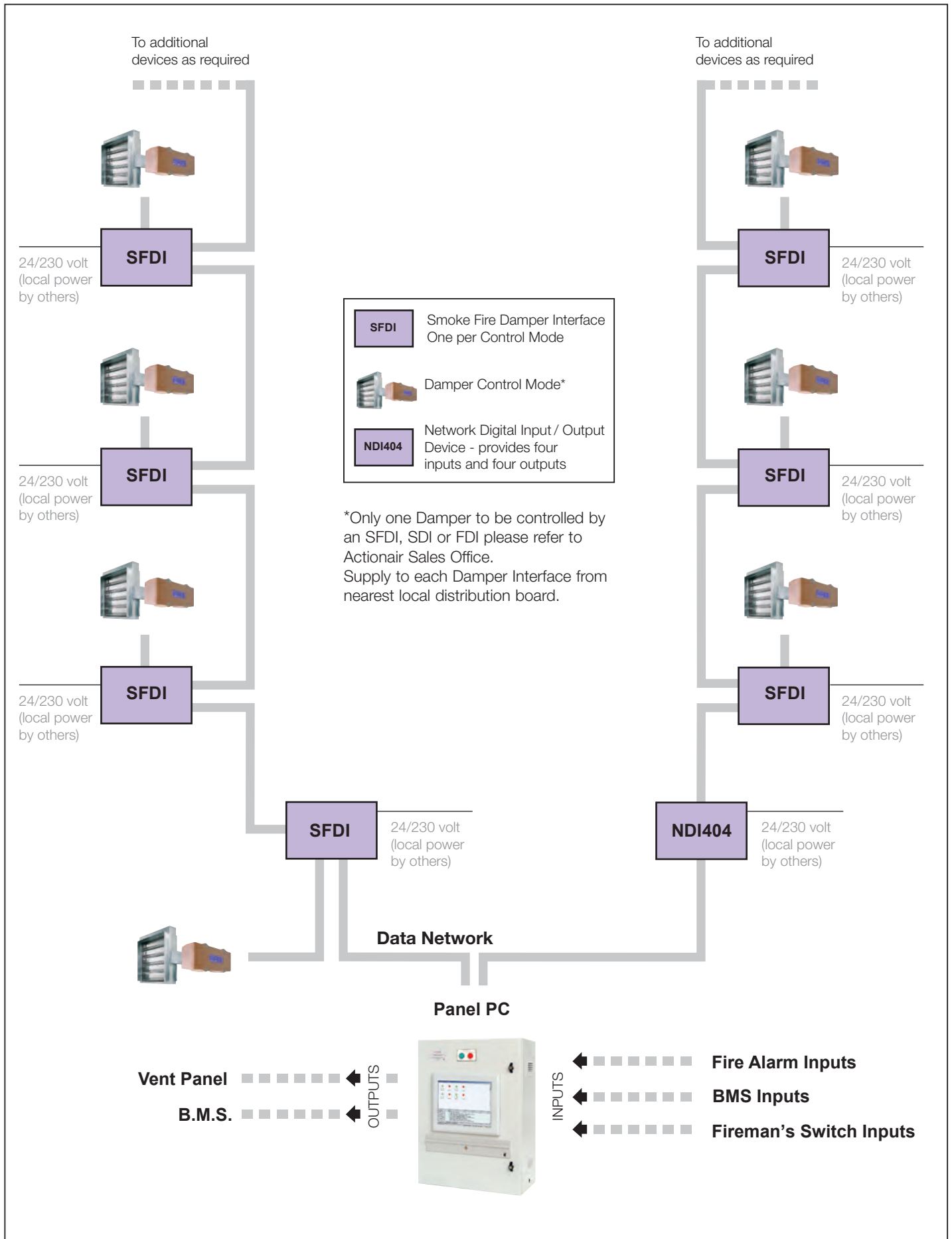

**Ruskin Air Management Limited
is a ISO 9001 and 14001 registered
company.**

The statements made in this brochure or by our representatives in consequence of any enquiries arising out of this document are given for information purposes only. They are not intended to have any legal effect and the company is not to be regarded as bound thereby. The company will only accept obligations which are expressly negotiated for and agreed and incorporated into a written agreement made with its customers.

Due to a policy of continuous product development the specification and details contained herein are subject to alteration without prior notice.

**Comprehensive and detailed information
is available for all Actionair products.
Visit our website at www.actionair.co.uk**

Ruskin Air Management Limited

South Street, Whitstable, Kent
CT5 3DU England.
Tel: 01227 276100
Fax: 01227 264262
Email: sales@actionair.co.uk
Website: www.actionair.co.uk

actionair
Dampers Controls Fancoils